

otopné trubkové těleso "PRIMO RONDO-N"

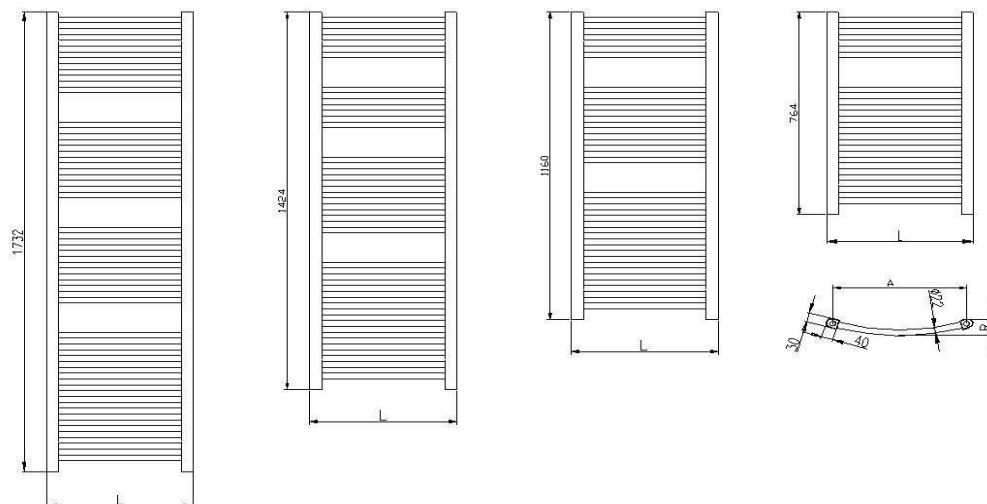

Charakteristické údaje:

Šířka	L	(mm)	400	500	600	750
Výška	H	(mm)	764	1160	1424	1732
Připojovací rozteč	A	(mm)				
Zkušební přetlak	p	(MPa)		1,3		
Pracovní přetlak	p	(MPa)		1,0		
Hloubka	R	(mm)				
Připojení spodní x středové DN			G 1/2" vnitřní			

Základní materiál:

Ocelový profil 30 x 40 x 1,5
 Ocelová trubka \varnothing 22 x 1,2 mm
 Včetně příslušenství
 Záruka 5 let na otopné těleso

Povrchová úprava:

standard RAL 9016
 RAL
 chrom (pozn. jen šířka 500 a 600 mm)

PRIMO RONDO-N
Tepelný výkon Q (W) a technické parametry
RAL

Typové označení	Šířka L (mm)	Výška H (mm)	Hloub. R (mm)	Rozteč A (mm)	tw1/tw2 = 90/70 (°C) při t1 (°C)					Obsah vody (l)	Hmotnost (kg)	Přestupní plocha SL (m ²)	Dopor. výkon el. topného tělesa (W)
					tw1/tw2 = 75/65 (°C) při t1 (°C)								
					tw1/tw2 = 55/45 (°C) při t1 (°C)								
					15	18	20	22	24				
NR-03-400.0764-44-01	400	764	47	360	398	375	359	343	328	2,6	5,1	0,526	200
					319	300	287	275	262				
NR-03-500.0764-44-01	500	764	54	460	479	450	431	412	394	3,1	6,0	0,630	300
					382	359	344	329	314				
NR-03-600.0764-44-01	600	764	57	560	555	522	500	478	456	3,6	6,9	0,733	300
					444	418	400	383	365				
NR-03-750.0764-44-01	750	764	64	710	672	632	605	579	553	4,2	8,3	0,889	400
					539	507	485	464	443				
NR-03-400.1160-44-01	400	1160	47	360	592	557	534	510	487	3,9	7,7	0,782	300
					474	446	427	408	390				
NR-03-500.1160-44-01	500	1160	54	460	710	668	639	611	584	4,6	8,8	0,934	400
					566	532	510	488	466				
NR-03-600.1160-44-01	600	1160	57	560	822	773	741	708	676	5,2	10,2	1,086	500
					658	619	593	567	541				
NR-03-750.1160-44-01	750	1160	64	710	993	934	895	855	817	6,5	12,4	1,314	600
					796	749	717	686	655				
NR-03-400.1424-44-01	400	1424	47	360	711	668	640	612	584	4,7	8,9	0,938	400
					568	535	512	490	468				
NR-03-500.1424-44-01	500	1424	54	460	848	798	764	731	698	5,7	10,8	1,117	500
					677	637	610	583	557				
NR-03-600.1424-44-01	600	1424	57	560	985	926	887	848	810	6,3	12,1	1,301	600
					788	742	710	679	649				
NR-03-750.1424-44-01	750	1424	64	710	1184	1114	1067	1020	974	7,4	14,3	1,567	700
					950	893	856	818	781				
NR-03-400.1732-44-01	400	1732	47	360	888	835	800	765	730	5,9	11,3	1,172	600
					710	668	640	612	584				
NR-03-500.1732-44-01	500	1732	54	460	1066	1003	961	918	877	6,9	13,2	1,403	700
					850	800	766	732	699				
NR-03-600.1732-44-01	600	1732	57	560	1232	1158	1110	1061	1013	7,8	15,0	1,627	800
					986	927	888	849	811				
NR-03-750.1732-44-01	750	1732	64	710	1489	1400	1341	1282	1225	9,2	17,9	1,970	1000
					1194	1123	1076	1028	982				

PRIMO RONDO-N
Tepelný výkon Q (W) a technické parametry
Cr

Typové označení	Šířka L (mm)	Výška H (mm)	Hloub. R (mm)	Rozteč A (mm)	tw1/tw2 = 90/70 (°C) při t1 (°C)					Obsah vody (l)	Hmotnost (kg)	Přístupná plocha SL (m ²)	Dopor. výkon el. topného tělesa (W)
					tw1/tw2 = 75/65 (°C) při t1 (°C)								
					tw1/tw2 = 55/45 (°C) při t1 (°C)								
					15	18	20	22	24				
NR-03-500.0764-44-07	500	764	54	460	252,1 134 366,3	236,9 126,1 344,5	227 120,8 330	217,1 115,5 315,5	207,2 110,2 301	3,1	6,0	0,630	200
NR-03-600.0764-44-07	600	764	57	560	293 146,5 443,5	275,9 137,9 417,1	264 132 399,3	252,8 126,1 382,1	240,9 120,8 365	3,6	6,9	0,733	200
NR-03-500.1160-44-07	500	1160	54	460	373,6 199,3 542,5	351,1 187,4 510,2	336,6 179,5 489,1	322,1 171,6 467,3	307,6 163,7 446,2	4,6	8,8	0,934	300
NR-03-600.1160-44-07	600	1160	57	560	434,3 217,1 655,4	408,5 203,9 616,4	391,4 195,4 590,7	374,2 186,8 564,3	357,1 178,2 539,2	5,2	10,2	1,086	300
NR-03-500.1424-44-07	500	1424	54	460	446,8 238,3 650,1	420,4 223,7 611,2	402,6 214,5 585,4	384,8 204,6 559,7	367,6 196 534,6	5,7	10,8	1,117	300
NR-03-600.1424-44-07	600	1424	57	560	520,1 260 781,4	489,7 244,9 735,2	468,6 234,3 704,2	448,1 223,7 673,2	428,3 213,8 642,8	6,3	12,1	1,301	400
NR-03-500.1732-44-07	500	1732	54	460	561 299 813,1	528 281,2 764,3	505,6 269,3 732,6	483,1 257,4 700,3	461,3 246,2 668,6	6,9	13,2	1,403	400
NR-03-600.1732-44-07	600	1732	57	560	650,8 325,4 982,7	611,8 305,6 924	586,1 293 885,1	560,3 279,8 846,1	535,3 267,3 808,5	7,8	15,0	1,627	500

Příslušenství- set plastový

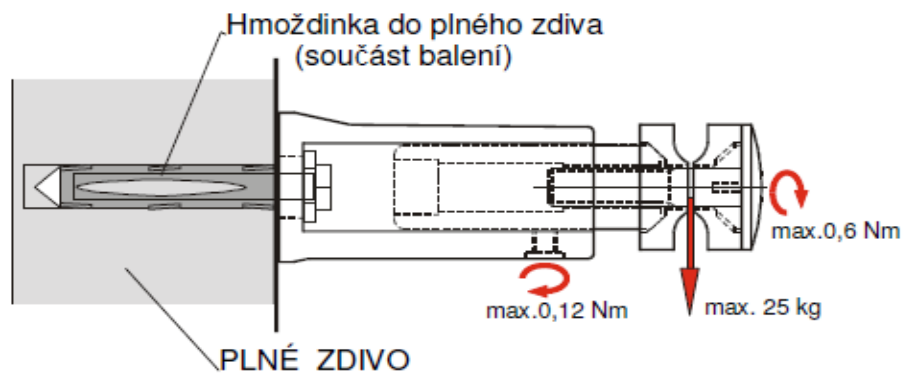

Zátka a odvzdušňovací šroub G1/2"



materiál: mosaz niklová
dotahovací moment max. 25Nm \pm 3Nm

